

devcom

Developer
Conference
2022

August 21-26, 2022

Congress Center East at Koelnmesse,
Cologne, Germany



Who We Are!

Connect with Europe's most experienced gaming professionals!

"We are so excited to be meeting everyone in person again this year in Cologne – and our enthusiasm is echoed throughout the industry. People want – and need – to see each other again."

Stephan Reichart, MD of devcom

#ddc2022: the official Game Developers Conference of gamescom

devcom is the official game developer event of gamescom and Europe's biggest game developer community-driven industry conference.

Offering additional content and events throughout the year, devcom constantly emphasizes its core values of diversity, inclusion and sustainability.

Europe's biggest game developer conference will again offer a wide range of events and sessions for international game developers, game publishers and service providers.

#ddc2022 will be a fully hybrid event.

This year's program features a pot-pourri of high-quality talks, panels, fireside chats and workshops, delivered by dozens of industry experts across (currently) six live stages on August 22 & 23.

The conference will be followed by a devcom-hosted live Twitch studio and exclusive attendee space in the B2B expo area at gamescom from August 24-26.

130+
sessions

3,000+
attendees

250+
speakers

180
publishers

Key Numbers

130+
journalists

43%
game
developers

60
curated
Indie Teams

Key Features

12 topics

on 6 stages

Fully Live

all sessions will be
streamed live

2 expo floors

Main Area & Indie Area

Daily Twitch Show

live from gamescom's b2b area

Networking

through numerous activities
organized by partners

Analytics

lead-generation connected to
all sponsors & exhibitors

Meeting area

dedicated for business meetings

Daily Twitch Show

9.6M

minutes watched

2.4M

views on Twitch

80k+

max viewers

1.4M

unique viewers



CONTENTS



1. Timeline	7
2. Demographics & Statistics	8
3. Key Speaker & Sponsors	11
4. Sponsoring Options	14
5. Exhibitor Options (On-Site & Booths)	16
6. Exhibitor Options (Digital)	17
7. Contacts	22

devcom Developer Conference

August 22 - 26, 2022

on-site & online
devcom.global



Pre-Event

August 21
Sunday

August 22
Monday

August 23
Tuesday

August 24
Wednesday

August 25
Thursday

August 26
Friday

devcom Developer Conference
Monday & Tuesday

gamescom b2b
Wednesday to Friday

Executive Summit
2pm - 5pm CEST

devcom streaming studio
Wednesday to Friday

GIGA Ceremony
6pm - 8pm CEST

devcom lounge
Wednesday to Friday

Networking Dinner
from 8pm CEST

Sunset Mixer Party
from 8pm CEST

Indie Developer Night
from 8pm CEST

Pitch it! - SUMMER EDITION
10am - 6pm CEST

ONLINE: SwapCard opens
starting August 8th

ONLINE: 5 weeks of meeting agendas
starting August, 8th to September Sunday, 11th

Agenda Overview

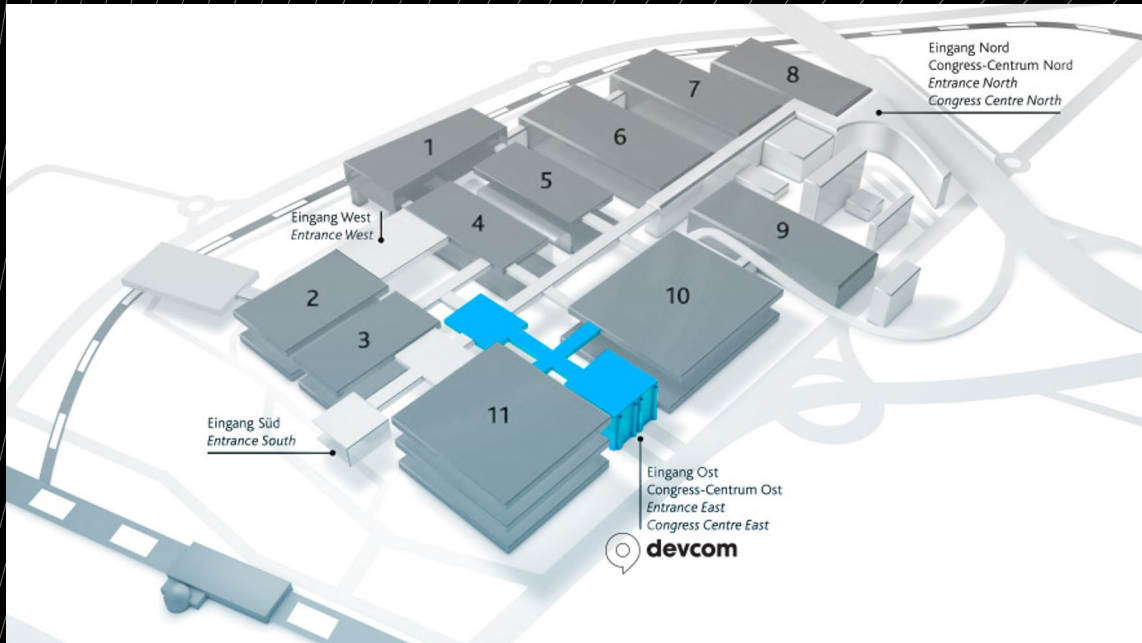

devcom LOCATION

DEMOGRAPHICS & Statistics

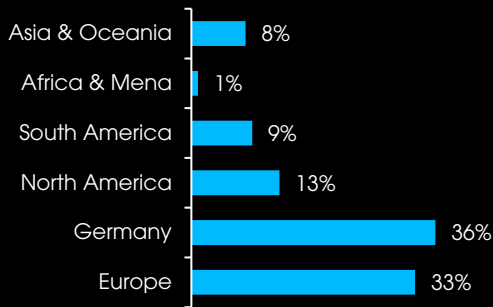

Geographical Breakdown

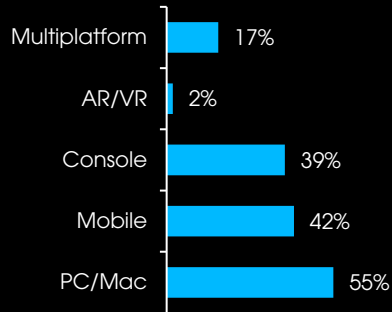

Platform

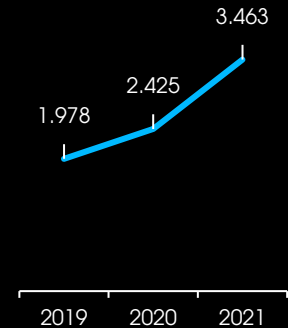

Attendees

DEMOGRAPHICS & Statistics

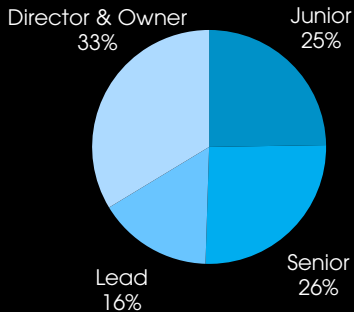

Seniority Level

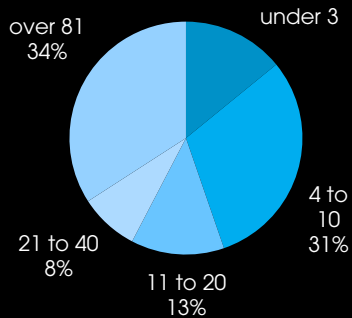

Company Size
(employer count)

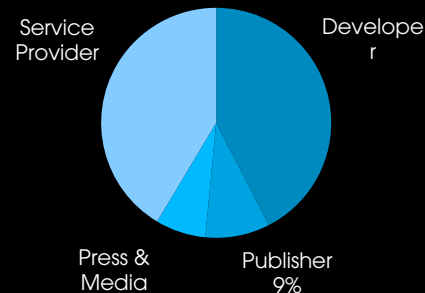

Company Activity

DEMOGRAPHICS & Statistics

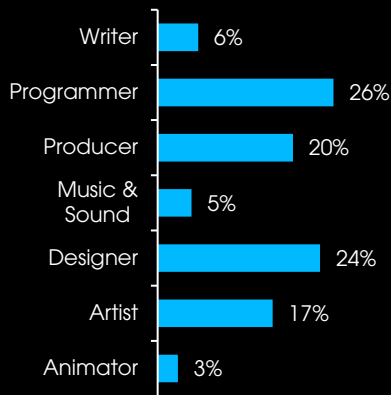

Production Roles

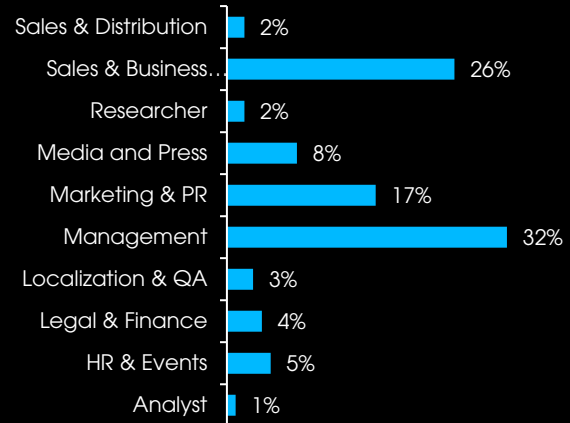

Non-Production Roles

SPEAKER

Highlights 2021

Yoko Taro

CEO & Managing Director, Game Director & Creative Director at Bukkoro Co., Ltd

Ashly Burch

Writer & Actress

Yosuke Saito

Member of the Board, Executive Officer & Executive Producer at Square Enix Ltd

Carlos Rocha Silva

CEO
Dreams Incorporated

Marta Fijak

Creative Director & Game Designer
Anshar Studios

Dave Gibbons

Art Director, Illustrator & Writer

Charles Cecil

CEO & Founder
Revolution Software

Jenna Ruth

VFX Artist
Insomniac Games

Navid Khavari

Narrative Director
Ubisoft

Anne Toole

Writer
The Write Toole

Macha Lopez

Lead Narrative Designer
DONTNOD Montréal

Saki Ito

Development Director
Toylogic Co., Ltd

Glen Schofield

CEO
Striking Distance Studios

Lual Mayen

CEO & Founder
Junub Games, Lual Mayen Foundation

devcom Sales Deck

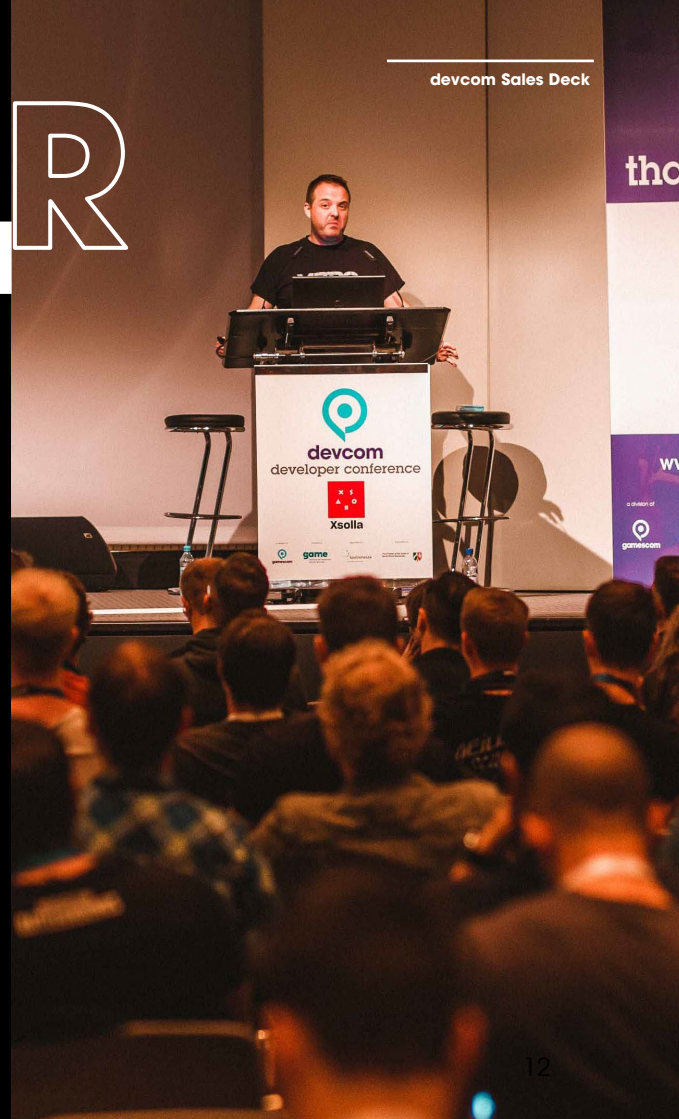

SPONSORS & Partners 2021

UBISOFT
BLUE BYTE



SQUARE ENIX.



INSOMNIAC
GAMES

ZeniMax[®]
MEDIA INC.



COUNTRY PAVILIONS & Delegations 2021



SPONSORING



Exhibition Space
Boost your visibility by presenting your services & products onsite.

devcom Twitch Channel
Your presence in our Daily Twitch Show before, during and after devcom.

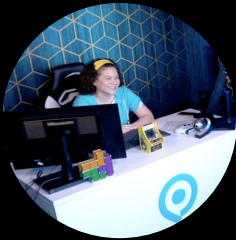

Event & Matchmaking App
Access our matchmaking system and book all your meetings in one place.

Online, Onsite & Print
Make sure you have the right visibility to hit the tone at #ddc2022.



Conference & Program
Brand a stage or go for a sponsored session. Make yourself visible to all attendees.

Newsletters & Social Network
Your shout-outs to our community on all our communication platforms.



FLOOR MAP

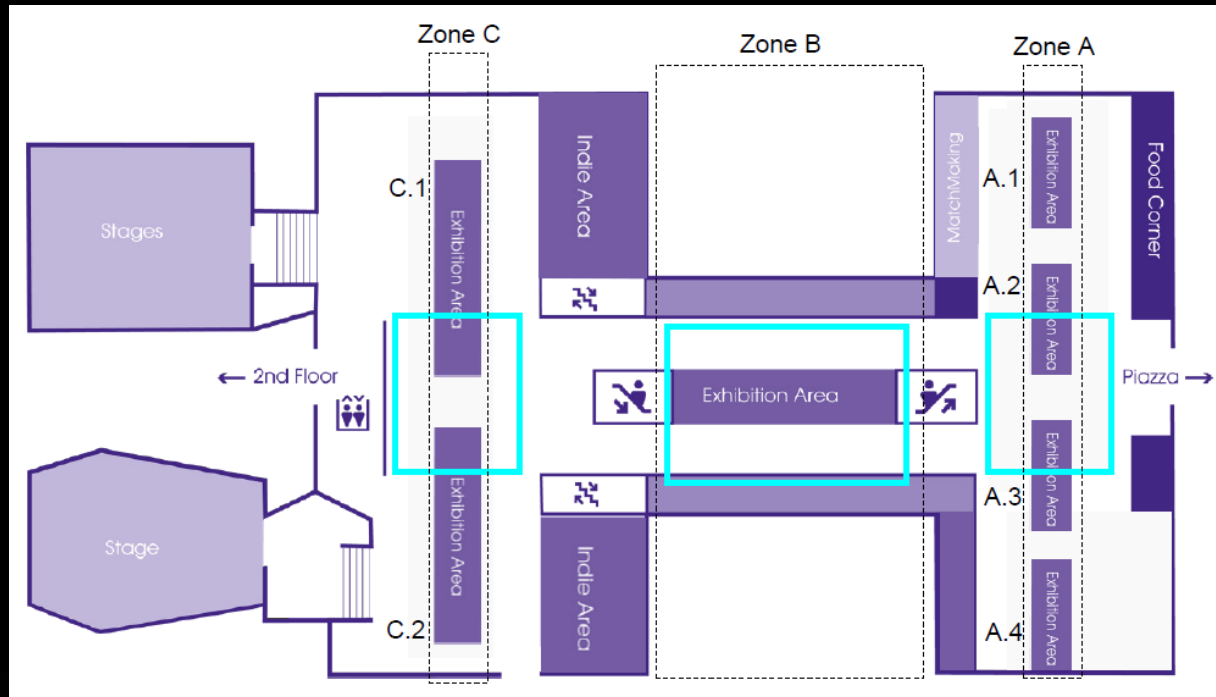

Premium traffic



Country Pavilions & Delegations

IN-APP APPEARANCE

Dedicated Country Pavilion Page

With basic information, customized header and background image, trailer, booklets

Dedicated Exhibitor Page

For every company with basic information, customized header image, trailer, booklets

PASSES

per company

4 Business Pass

4 Content Pass

LEAD RETRIEVAL

per company

Virtual booth visits

see booth visitors

PRODUCTS & SERVICES PROMOTION

per company

Main showcase

add 1 product

ACCESS & DOWNLOAD REPORTS OF CONTACTS THAT

per company

...connected with exhibitor's team members.

...had a confirmed meeting with exhibitor's team member.

...had a chat conversation with exhibitor's team members.

...visited or bookmarked the exhibitor page

... visited or bookmarked exhibitor's products or services

...downloaded exhibitors' booklet

TIER BASED PRICING

Prices are per unit

up to 5 companies 1,200 €

6 to 10 companies 1,120 €

11 to 15 companies 1,068 €

16 to 20 companies 999 €

more than 21 companies 880 €



EXHIBITOR

On-Site



Dimensions	2x6 m	2x3 m	2x2 m
Booth structure	✓	✓	✓
Booth branding	✓	✓	✓
Power supply	✓	✓	✓
Carpet	✓	✓	✓
Furniture inc.	1 long table + 4 bar stools + 1 counter	1 round table + 4 bar stools + 1 counter	1 table + 2 chairs
VIP & Networking Pass	1	X	X
Business Pass	5	4	2
Content Pass	4	2	2
Digital Visibility Pack (Regular)	✓	✓	✓
Early Bird (Ends Jun. 30)	12,650 €	7,700 €	5,250 €
Regular	14,750 €	9,000 €	6,250 €

EXHIBITOR

On-Site



Dimensions	5x6 m	5x4 m
Booth structure	✓	✓
Booth branding	✓	✓
Power supply	✓	✓
Carpet	✓	✓
Furniture inc.	3 high tables + 6 bar stools + 1 sideboard + 1 coffee table + lounge chair	4 high tables + 8 bar stools + 1 sideboard
Digital Visibility Pack <small>(Regular)</small>	✓	✓
Price	28,500 €	21,900 €
Booth without furnitures	24,400 €	18,100 €

EXHIBITOR

Additional

Speaking Slot

A 30 min speaking slot incl. Q&A

From 15,000 €

A 60 min speaking slot incl. Q&A

From 25,000 €

Private Meeting Room

Meeting Room in the Mezzanine level with standard set of furniture (1 table + 4 chairs)

500 € / day

Equipment available

LCD-TV 55" plus Pedestal

640 €

Booth carpet of another color (per sqm)

33.75 €

Booth digital foil (per sqm)

108 €

Furniture catalogue

Contact Sales Team

PLATINUM LEVEL

Exhibitor Online

Access & download of **all reports** on your digital exhibition space

Premium **Lobby visibility** including 1 banner and 1 ad

In-app communication

Fully customizable dedicated **exhibitor page**

Lead retrieval including onsite badge reader and virtual booth visits

PASSES

Business Pass	30
Content Pass	20
Price	26,000 €

PRODUCTS / SERVICES PROMOTION

Main Showcase <small>Add product</small>	5
Jobs Board <small>Add posts</small>	Unlimited

As an **onsite** exhibitor you have the Regular level included into your booth.
You can **upgrade** to the Platinum level for **15,000 €**

GOLD LEVEL

Exhibitor Online

Limited access & download of the reports on your digital exhibition space

Lobby visibility including 1 logo in the grid and 1 ad

Customizable dedicated exhibitor page

Lead retrieval including onsite badge reader and virtual booth visits

PASSES

Business Pass 20

Content Pass 15

Price 16,000 €

PRODUCTS / SERVICES PROMOTION

Main Showcase 3
Add product

Jobs Board 20
Add posts

As an onsite exhibitor you have the Regular level included into your booth.

You can upgrade to the Gold level for 8,000 €

SILVER LEVEL

Exhibitor Online

Limited access & download of the **reports** on your digital exhibition space

Customizable dedicated **exhibitor page**

Lead retrieval including onsite badge reader and virtual booth visits

PASSES

Business Pass	10
Content Pass	8

Price 10,000 €

PRODUCTS / SERVICES PROMOTION

Main Showcase <small>Add product</small>	2
Jobs Board <small>Add posts</small>	16

As an **onsite** exhibitor you have the Regular level included into your booth.
You can **upgrade** to the Silver level for **5,000 €**

REGULAR LEVEL

Exhibitor Online

Basic access & download of the **reports** on your digital exhibition space

Dedicated **exhibitor page**

Lead retrieval including onsite badge reader and virtual booth visits

PASSES

Business Pass 4

Content Pass 4

Price 5,000 €

PRODUCTS / SERVICES PROMOTION

Main Showcase 1
Add product

Jobs Board 1
Add posts

As an **onsite** exhibitor you have the Regular level included into your booth.

SPONSORING

Overview

NETWORKING

page 25 - 28

Networking Dinner	85,000 €
Indie Developer Night	85,000 €
Sunset Mixer Party	43,700 €
Executive Summit	35,700 €

FOOD & BEVERAGES

Page 29 - 34

Official beverage sponsor	63,200 €
Official food sponsor	63,200 €
Cocktail reception (2 available)	37,600 € each
Barista coffee stand	22,700 €
Grilled sausage stand	13,400€
Beer reception (2 available)	10,925 € each
Ice cream stand	9,375 €
Fruit bowls	5,600 €

CONFERENCE

Page 35 & 36

Keynote stage (350 PAX)	45,000 €
Medium stage (70 PAX) ³ available	26,000 €
Small stage (50 PAX) ² available	18,600 € each
Workshop (50 PAX)	12,600 €

EVENT

Page 37 - 46

Speaker GuestClub	61,200 €
Wifi provider	50,000 €
Registration sponsor	50,000 €
Indie Award	45,000 €
Volunteer area	33,600 €
Outdoor lounge	25,500€
Indoor lounge	25,500 €
Business area	25,000 €
Volunteers' t-shirt	17,500 €
Restroom ads	16,300 €
Goodie bag	15,500 €
Charging station	15,200 €
Lanyards	11,100 €
Cargo bike	9,500€
Logo on goodie bag	5,000 €
Insert in goodie bag	2,500 €

VENUE VISIBILITY

Contact Sales Team for full overview

Main entrance banner	15,000 €
Piazza balustrade (2 sides)	6,000 € / side

SPONSORING

Overview

GIGA CEREMONY

Contact Sales Team for full overview

Platinum (page 47)	18,230 €
Gold	9,120 €
Silver	4,560 €
Bronze	900€

TARGETED PROMOTION

Contact Sales Team

Attendee email (2 available)	8,000 €
Dev or Pub email (2 available)	5,000 €
Newsletter 7,000 recipients (2 available)	4,000 €
Notifications through event app	4,000 €
Short text insert in newsletter	1,500 €

STREAMING STUDIO

Contact Sales Team

Co-partner - full branding	99,000 €
120 min interview	7,450 €
60 min interview	4,000 €
90 sec trailer (2 available)	7,500 €
60 sec trailer (2 available)	5,700 €
30 sec trailer (2 available)	3,000 €
Intro trailer 60 sec (2 available)	9,000 €

Outro trailer 60 sec (2 available) 7,500 €

Banner overlay lower third (during sponsored session & community time) 25,000 €

Banner overlay lower third (during community time) 15,000 €

Bumper ads / logo (displayed 3 time a day) 7,000 €

Corner logo (permanent display) 25,000 €

Logo guest name (permanent display) 15,000 €

Logo on main overlay (permanent display) 8,000 €

DEVCOM BUSINESS LOUNGE

Contact Sales Team

Catering sponsor 25,000 €

Reserved meeting table 2,700 €

PITCH IT! SUMMER EDITION

Contact Sales Team

Main partner 19,000 €

Logo on booklet cover page 2,750 €

Visibility pack 4,000 €



networking dinner

Sunday, 21st from 7pm until midnight

Location: Restaurant in Cologne, Germany

- Exclusive location booked for 250 guests
- Fine dining experience including wine
- Logo on menu cards placed on each table
- Sponsor's business cards placed on each guest's plate
- Logo on email invitations sent to all guests
- 20 free invitations to give away
- Included into event agenda
- Website and social media announcements
- Lead scanner at the entrance

85,000 €

Possible to bring co-sponsor(s)



sunset mixer party

Monday, 22nd from 8pm until midnight

Location: Piazza, KoelnMesse

- 1,500 beer bottles
- DJ for 4 hours
- sound & light system
- photo box with sponsor logo on backdrop
- rollup banners
- balloons decorations
- included into event agenda
- website and social media announcements
- lead scanner at the entrance

43,700 €

Possible to bring co-sponsor(s)



indie developer party

Tuesday, 23rd from 8pm until midnight

Location: Club in Cologne, Germany

- 3,000 beer bottles
- DJ for 6 hours
- sound & light system
- photo box with sponsor logo on backdrop
- rollup banners
- logo on tables sign
- included into event agenda
- website and social media announcements
- lead scanner at the entrance

85,000 €

Possible to bring co-sponsor(s)

NETWORKING

Executive Summits



Tuesday 23rd from 2 – 6pm CEST
Congress-Centrum Ost Koelnmesse

executive
summit

main partner

- 35 to 50 CEOs and C-level only attendees
- Selected and invited from devcom's and gamescom's key accounts pool
- Cold & warm food and beverages
- Logo on napkins, logo on entrance door, logo on table signs
- Short text inserted in the welcome and thank you email
- 30 min keynote followed by a 30min Q&A sessions
- Included into event agenda and floor map
- Website and social media announcements

35,700 €



official food sponsor

- logo on all paper lunch bags and napkins
- logo on all F&B areas
- logo on menu cards
- included into event agenda and floor map
- website and social media announcements

63,200 €



cocktail reception

- 1,000 cocktails
- Monday or Tuesday, time of your choice (from 4pm CEST)
- either on your stand or outside on the Piazza
- included into event agenda
- website and social media announcements
- lead scanner at the entrance

37,960 €



barista coffee stand

- logo on cups
- backdrop with your design
- baristas wearing your t-shirt
- all coffee style
- coffee stand part of your booth!
- included into event agenda and floor map
- website and social media announcements

22,700 €



grilled sausage stand

- 500 portions
- Napkins & rollup banners
- either on Monday or Tuesday, from 2pm CEST
- included into event agenda and floor map
- website and social media announcements

13,400 €



beer reception

- 1,000 bottles of Kölsch or Becks
- Monday or Tuesday, time of your choice (from 2pm CEST)
- either on your stand or outside on the Piazza
- included into event agenda
- website and social media announcements
- lead scanner at the entrance

10,925 €

2 available

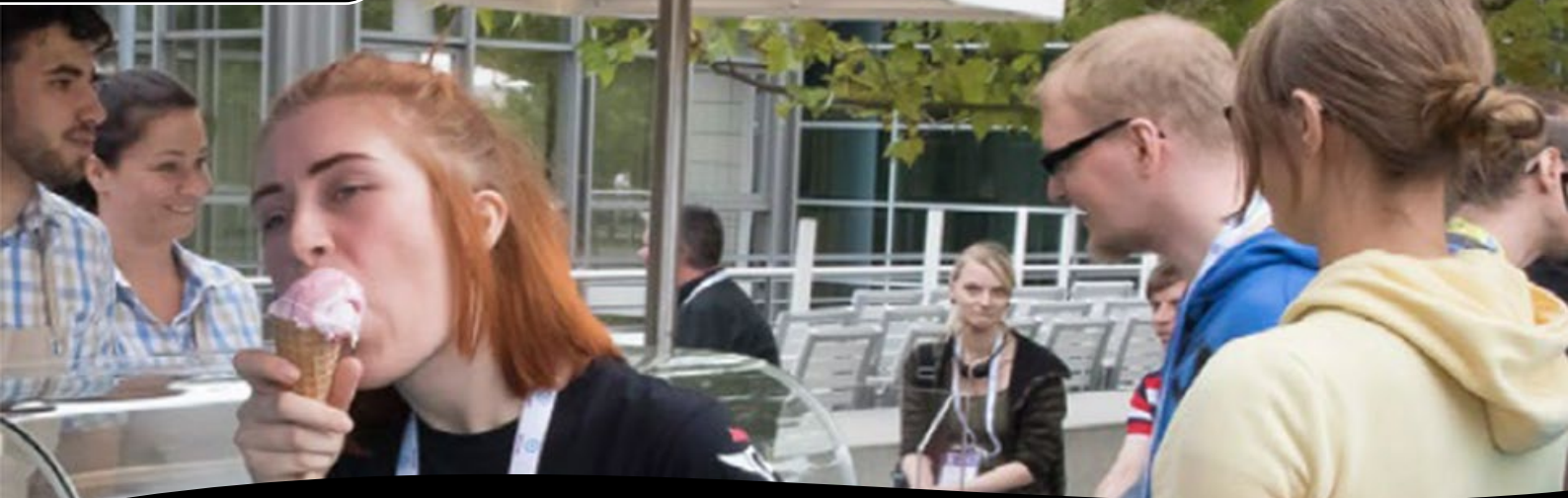

ice cream stand

- 500 ice cream cones ; 3 flavors
- napkins & rollup banners
- either on Monday or Tuesday, from 2pm CEST
- included into event agenda and floor map
- website and social media announcements

9,375 €

(500 scoops) Or **13,600 €** (1,500 scoops)



opening ceremony

- devcom Developer Conference 2022 opening ceremony sponsorship
- intergalactic Power Metal Opening from Outer Space
- StarLord / Guardians of the Galaxy Rock Band
- 400 attendees onsite / re-streamed online
- Monday 22nd, 10am to 10.30am CEST
- included into event agenda and floor map
- website and social media announcements

25,100 €



stage

sponsoring

(medium / small / workshop)

- logo on screensaver (in-between sessions)
- Roll up banner with logo
- included into event agenda and floor map
- website and social media announcements

From **26,000 €** to **12,000 €**



GuestClub

Speaker room

- 5 VIP & Networking Passes incl.
- full catering & hot and cold beverages all day long during devcom & gamescom
- logo on napkins
- logo on tables
- sponsor's business cards placed on each table
- logo on menu cards
- logo on entrance door

61,200 €



wifi provider

- Customized network name
- website and social media announcements

50,000 €



registration sponsor

- short text inserted in ticket confirmation email
- logo on ticket shop banner
- logo on e-ticket
- branded registration area
- website and social media announcements

50,000 €



indie award

- short text and logo on Call for Indies form
- 2 seats in the indie award jury
- early access to all participating projects
- direct introduction to participating studios of special interest through devcom
- visibility on all 20h of live let's play (aired on devcom Twitch channel)
- in person award give away
- logo on award
- website and social media announcements

45,500 €



volunteer area

- 200 volunteers present throughout ddc2022 and on all side-events
- branded area
- logo on all tables
- logo on floor map
- website and social media announcements

33,600 €



outdoor lounge

(Piazza)

- branded & furnished outdoor lounge area (pick up furniture you want)
- logo on floor map
- website and social media announcements

45,000 €



indoor lounge

- branded & furnished outdoor lounge area (pick up furniture you want)
- logo on floor map
- website and social media announcements

25,500 €



devcom
2019

Match Making Area



business area

- branded area
- logo on all meeting tables
- included into event agenda and floor map
- website and social media announcements

25,000 €



Volunteers t-shirt

- 200 volunteers present throughout ddc2022 and on all side-events
- partner is part of the t-shirt design (logo or full design)
- website and social media announcements

17,500 €



lanyards

- logo on lanyard (together with devcom)
- 2,000 to 3,000 lanyards
- website and social media announcements

11,100 €

THE GLOBAL INDUSTRY GAME AWARDS

POWERED BY



PRESENTED BY



GIGA ceremony

presenting sponsor

Ask the Sales team for the complete sponsoring packages

- Included in awards title (i.e. "GIGA brought to you by (your company)")
- Keynote feature (max. 15min)
- 2 min promotional video during show
- Recognized as food & beverage sponsor
- On-site visibility on tables and signage
- 30 tickets to the in-person gala
- Front row table reserved at the gala
- Featured spotlight & e-blast to our mailing list
- Recognized as main sponsor on all media
- Recognition as main sponsor in press coverage and event recap

86,590 €

Main Entrance

- Logo on main entrance banner
- Banner size: 16 m by 2.7m
- Total surface: 43.20 sqm

Ask the Sales team for the complete list of visibility items available

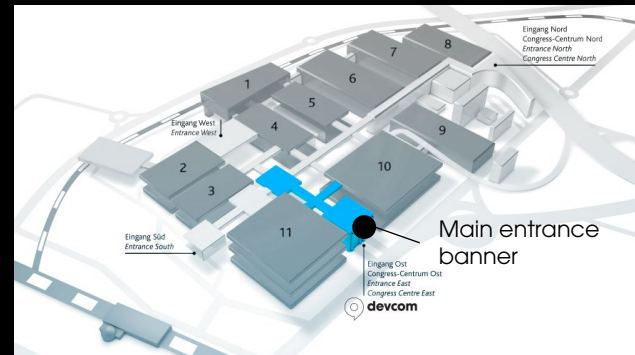

15,000 €

Piazza Balustrade

- Your design
- Banner size: 7.5 m by 0.8m
- Total surface: 6 sqm

Ask the Sales team for the complete list of visibility items available

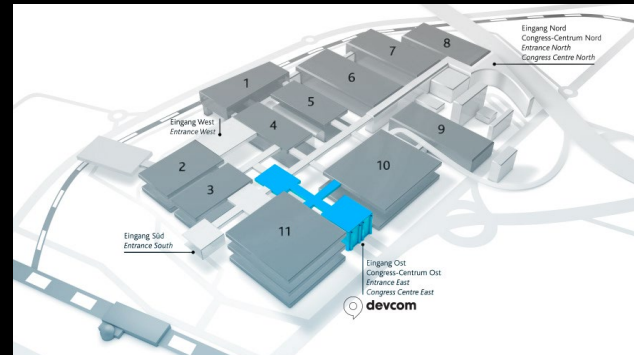

6,000 € / side

2 side available

Next step: Get in touch

Brand awareness, knowledge sharing, talent acquisition or generating leads. What is your highest priority? Or do you want it all? Get in contact with us for hand-fallosed offers!

We're looking forward to hearing from you!

Roufina Guenkova

(they/them)

Head of Sales
roufina@devcom.global

+33 6 84 21 58 54
+49 176 712 30 833



Astrid Gooding

(she/her)

Sales Manager DACH
astrid@devcom.global

+49 170 30 40 354



Thank
YOU!

